

MONSTER SET 4 - Assembly Instructions Page One. (For the BRIDE, the GROOM, and the REAPER)

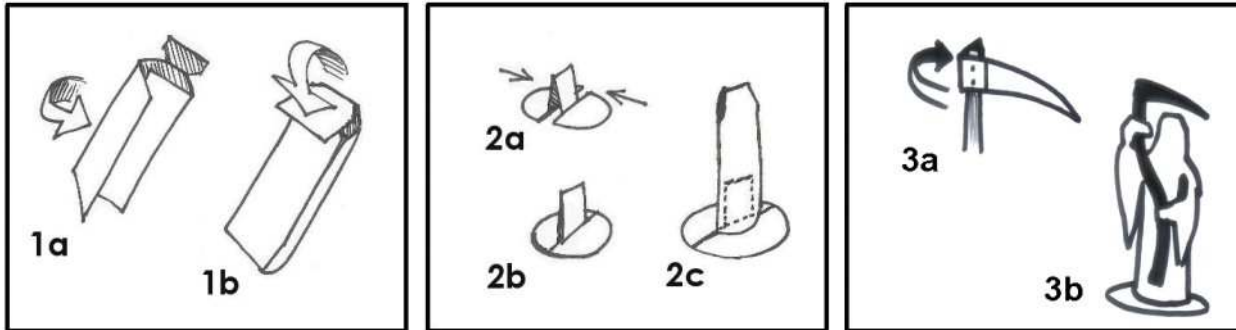

WHAT YOU'LL NEED: Scissors, an X-acto knife, glue (or a glue stick), and a ruler (or other straight-edge).
NOTE: These figures should be printed on Heavy Card Stock.

For each character: begin by cutting out the body section. Don't separate the panels, just snip out the entire piece. Fold the back panel and the blank panel down along the black lines. Smear some glue on the back of the back panel and glue it directly on top of the blank panel, allowing the front panel to curve slightly as shown in figure 1a. Next fold the top panel down along the black line and glue it over the back of the head as shown in figure 1b. You should now have a hollow body with a flat back and a curved front.

Next snip out the base piece. Fold the two half circles upward and then lay them flat and slide them together as shown in figure 2a. While holding them flat, press the two middle squares together and crease the top edge. Be sure the base sits flat on your tabletop, and then glue the two squares together. Cut out the large black square, place it face down, and glue the base on top of it. This will strengthen the base greatly, and will also make the finished model look more...well, you know...finished. Cut away the extra paper around the bottom circle to finish the piece. The base should now resemble figure 2b. Slide the base into the body and glue it to the inside BACK of the body section as shown in figure 2c. The monster's body should now stand upright.

Cut out the arm piece along the outer red lines (don't separate the two sides). Fold down along the blue center line and glue the two sides together. Then carefully cut away the white area around the arms. For the Bride, use the X-acto knife to carefully remove the white area from inside the arms.

Slide the arms down over the body and position the arms carefully. The black panel with the red dot should be placed against the back of the body, facing forward. For the Bride and Reaper, curve the arms where they cross the body so the arms rest against the front of the body. Glue the black panel (with the red dot) to the back of the body.

If you're building the Groom, he's now finished. For the Bride and the Reaper we'll add a few accessories...

MONSTER SET 4 - Assembly Instructions Page Two.

For the bride, cut out the flowers along the outer red lines (don't separate the two sides). Fold down along the blue center line and glue the two sides together. Cut away the outer white area. Now position the flowers behind the bride's hands so that the flowers are above the hands and the ribbons hang below them. Glue the Flowers to the back of the hands. Gently curve the arms and sleeves if necessary so they hang properly. The Bride is now complete.

For the Reaper, Cut out the sickle along the outer red lines (without separating the two sides). Fold down along the blue center line and glue the two sides together. Cut away the white area around both the handle and the blade. The blade has two mounting panels. With the point facing to the right, fold down along the red line, and crease sharply. Hold the handle with the red dot at the top, facing you, and wrap the blade's mounting panels around the handle as shown in figure 3a. Glue the panels to the handle (and each other) to finish the sickle. Place the sickle in position (as shown in figure 3b) and glue the handle to the back of the hands. Be sure to fold the left wrist so the left hand rests flat on the handle. Curve the left arm if necessary. And now the Reaper just needs his hourglass.

Cut out the hourglass and fold down along the red center line. Fold up along both green lines. Glue the two hourglass sides together (but don't glue the round half-circles). Cut out the small black square on Reaper Page 2 and place it face down. Position the hourglass as shown in figure 2b and glue the round base to the back of the black square. Trim away the white area around the base to finish the hourglass. And that completes the Reaper.